

A RELIABLE PROCESS FOR EFFICIENT LUBRICATION SOLUTIONS TAILORED TO YOUR NEEDS

FUCHS SOLUTIONS

Lubrication

Digitalization

Services

FUCHS PROCESS



Understand
Assess and analyse



Develop
Plan and set up



Manage
Implement and
operate



Optimize
Fine-tune and reuse

FUCHS & DMG MORI

ALL IN ONE - solutions for SEMICONDUCTOR applications



Machine

DMG MORI

- 5X-Champion
- Milling – Turning – Grinding
- µPrecision (3 µm)
- Automation
- Digitization
- Reduced zinc, copper and brass content

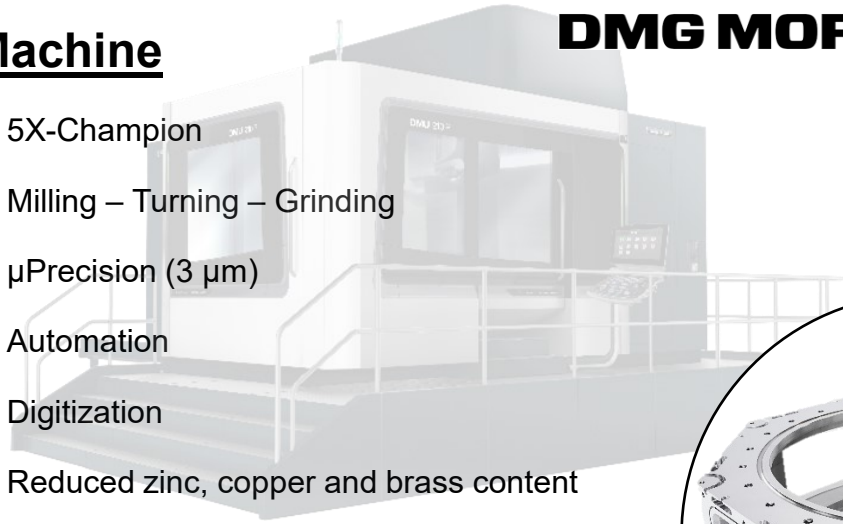

Lubricants

- High performance lubricants for high productivity
- Tailor made coolants for SEMICON industry
- Cleaners, hydraulic oils and specialties
- FUCHS lubricants are tested and approved by DMG MORI

DMG MORI QUALIFIED PRODUCTS

Customization

- Tailor made lubricant / coolant development
 - ECOCOOL SCS-IDM (synthetic coolant)
 - ECOCOOL SCE-IDM (semi-synthetic coolant)
 - ECOCOOL SCG-IDM (for USLT) **!!NEW!!**
- Customer support to reach GRADE 1 requirements
- Free of prohibited elements for GRADE 1

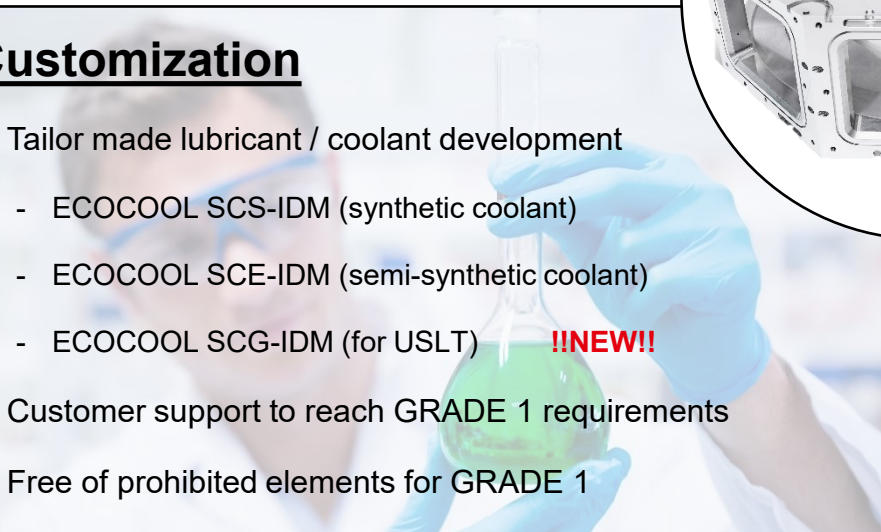

Technology

- State of the art lubricants
- Fluids Connect
- Product support with R&D
- On-site service support
- Global technology support

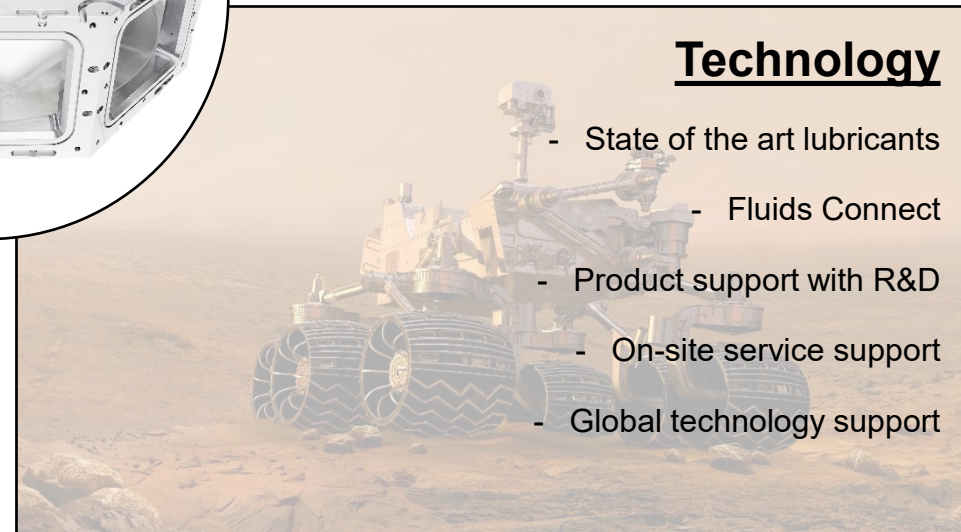

FUCHS' offer for the manufacture and operation of equipment for semiconductor production

Machining & Protection

Your reliable lubrication solutions-partner for **GRADE 1** Processes

High Performance, ready-to-use coolants for **GRADE 2** Processes

ECOCOOL GLOBAL 10
ECOCOOL GLOBAL 1000

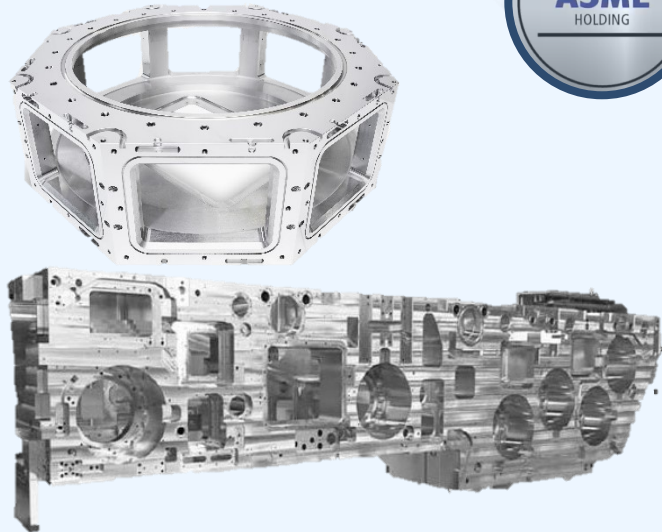
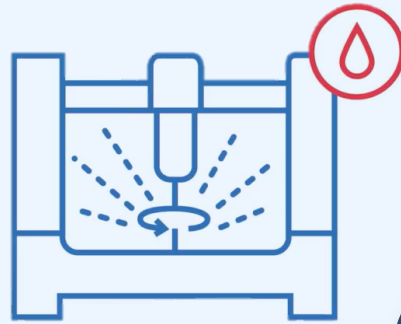

Vacuum & Clean Room applications

NYE LUBRICANTS
- speciality greases
- speciality fluids
- speciality coatings

NYETORR®
NYECLEAN®
NYEVAC®

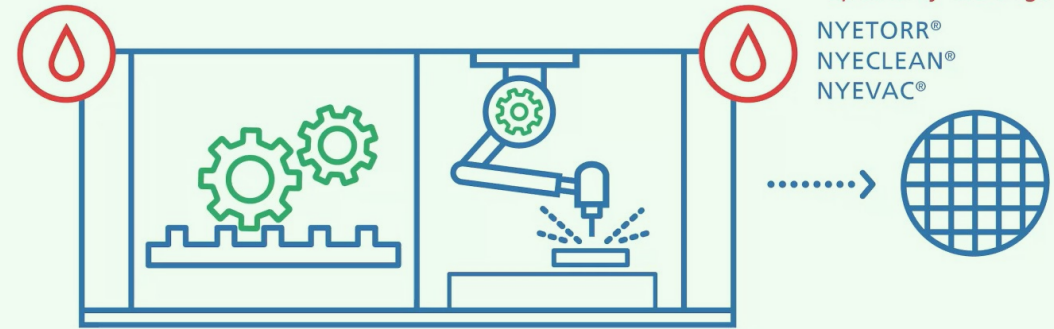

GRADE 1 processes



Tailor made solutions

ECOCOOL SCE-IDM
ECOCOOL SCS-IDM
RENOCLEAN "HiO"
ANTICORIT

GRADE 2 – 5 products



High performance metal working fluids

ECOCOOL GLOBAL 1000

Lubrication



Specialty greases Specialty fluids Non-stick coatings

NYETORR®
NYECLEAN®
NYEVAC®